

SAGA

EYE-CATCHING AND ECONOMICAL PASTRY CABINET



THE SIGN OF COOL QUALITY

SAGA



Saga-135-M-HC for chocolates

AN ELEGANT DISPLAY FOR DELICATES

Saga is a cost effective and reliable display. Due to its unique and functional features it actually is a profitable investment



Line of Sagas at Eliseevsky, Moscow



CAREFULLY CONTROLLED TEMPERATURE AND UNIQUE DESIGN

- Every shelf is refrigerated
- Top shelf is separately illuminated and lighting is provided under every shelf
- Panoramic curved glass and the glass shelving show the products inside at their best
- Saves floor space because the display area is large in relation to the floor area occupied by the cabinet



IDEAL FOR STYLISH DISPLAYS

Pastries

Cream cakes and gateaux

Dainty puff pastries

Savouries, sandwiches and pâtés

Fresh salads

Take-away treats

Pizza

Freshly baked bread

Confectionery and patisseries

Fresh chocolate creations

SAGA



MODELS

- Colour options: oak and stainless steel, the shelf brackets and the front shelving rail in the stainless steel models are stainless steel, while in the oak version they are gold in colour. In the hot counter the interior is always stainless steel.
- Rectangular refrigerated display cabinets with integrated machinery unit, for remote installation or without refrigeration, in lengths of 90 cm and 135 cm
- 45° external corner section service cabinet (ambient)
- Rectangular extension desk 90 cm
- 45° external and internal corner sections for extension desk



Saga-90-H hot counter

Saga line at
Stockmann



- Top shelf is separately illuminated and lighting is provided under every shelf
- Temperature range +2...+4°C or +6...+8°C
- Special HC version has selectable temperature range: +2...+8°C for pastries or +15...+18°C for chocolate products
- Saga hot counter in length 90 cm, with 3-shelves. Temperature area +65 .. +80 °C.



Saga hot counter -
sliding plane deck tray

SAGA-90-135-M

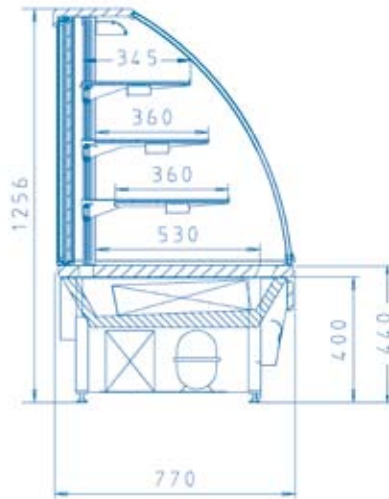

SAGA EXTENTION DESK

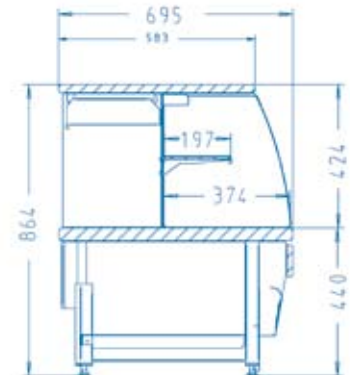

SAGA-90-H HOT COUNTER

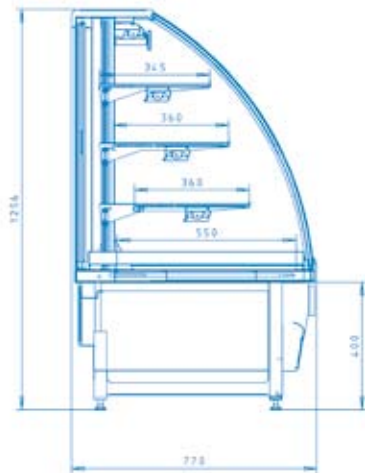

SAGA PASTRY LINE

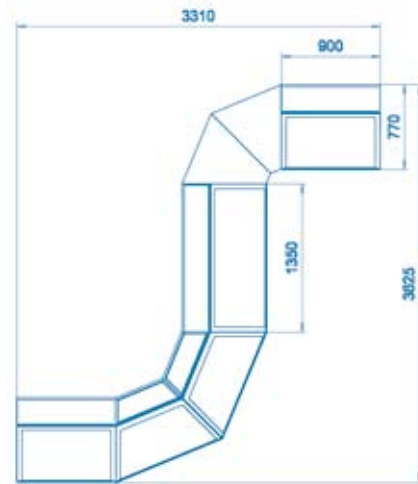

TECHNICAL DATA

CONSTRUCTION

Bearing structure and outer shell made of galvanized steel and anodized aluminium. Adjustable tubular legs and adjustable plinth panels. The panoramic front glass panel can be opened. Three steplessly adjustable and inclinable (0...7°) raised glass shelves. Sliding glass doors in rear of cabinet also made of thermo glass.

REFRIGERATION

Temperature adjustment range +2°...+8°C, refrigerant R404A. Cabinets with an integrated machinery unit are equipped with a fan evaporator. The evaporator is located in the base of the cabinet. The cabinet is provided with an electronic operating thermostat (control and limiter thermostat, defrosting timer, temperature display) and automatic electrical defrosting. Cabinets for remote installations are provided with an evaporator and an expansion valve. Connection points are situated in the machinery compartment. The speed of air circulation is optimized in all models.

TECHNICAL SPECIFICATIONS

MODEL	LENGTH mm	HEIGHT mm	DEPTH mm	POWER INPUT [W]	DISPLAY AREA m ²	AIR TEMPERATURE
SAGA-90-M	900	1256	770	520	1.5	+2...+8
SAGA-90-M-HC	900	1256	770	720	1.5	+15...+18
SAGA-90-o	900	1256	770	320	1.5	+2...+8
SAGA-90-o-HC	900	1256	770	320	1.5	+15...+18
SAGA-90-W	900	1256	770	80	1.5	
SAGA-135-M	1350	1256	770	785	2.3	+2...+8
SAGA-135-M-HC	1350	1256	770	1085	2.3	+15...+18
SAGA-135-o	1350	1256	770	525	2.3	+2...+8
SAGA-135-o-HC	1350	1256	770	525	2.3	+15...+18
SAGA-135-W	1350	1256	770	160	2.3	
SAGA-EA-45-W	1043	1256	715	80	1.0	
SAGA-PP-90	900	860	750		0.5	
SAGA-PP-EA-45	1043	860	695		0.4	
SAGA-PP-IA-45	1043	860	695		1.0	
SAGA-90-H (+65..80 °C)	900	1256	770	1600	1.5	+65...+80

Technical specifications at ambient temperature of +25 °C and relative humidity of 60 %. Connection voltage 230 V, single-phase, 50 Hz.

STANDARD FITTINGS

- 3 steplessly adjustable and inclinable (0...7°) raised glass shelves with front rails
- Shelf lighting
- Top lighting
- Protective film on fluorescent tubes to prevent spreading of glass fragments in case of breakage
- Long Life (LL) fluorescent tubes in all models

OPTIONAL FITTINGS

- Shelf for bags
- Sliding shelf for cream cakes

STANDARD FITTINGS FOR THE HOT COUNTER

- Infrared tube heaters in the shelves
- Rod heaters below the deck trays
- Two sliding plane deck trays
- Water container with slotted lid

SPECIAL VERSION FOR CHOCOLATES

- Controller to maintain an even humidity of 50 %
- Temperature range +15...+18°C
- Keeps expensive and delicate products in prime condition
- Humidity controller can be fitted to cabinets with integrated machinery and to remote installations



Norpe Ltd. Tel. +358 19 537 8000
www.norpe.fi • www.norpe.com • marketing@norpe.fi

FINLAND Norpe Suomi Oy Tel. +358 19 537 8000
www.norpe.fi • www.norpe.com • marketing@norpe.fi

SWEDEN Norpe AB Tel. +46 8 594 112 00
www.norpe.se • info@norpe.se

NORWAY Norpe AS Tel. +47 33 36 35 00
www.norpe.no • post@norpe.no

POLAND Norpe Polska Sp. z o o. Tel. +48 22 882 00 20
www.norpe.pl • norpe@norpe.pl

GREAT BRITAIN Norpe UK Limited Tel. +44 161 968 5080
www.norpe.co.uk • info@norpe.co.uk

RUSSIA Norpe Russia Tel. +7 812 273 3912
www.norpe.com.ru • sale@norpe.spb.ru

ESTONIA Norpe Eesti Oü Tel. +372 656 1717
www.norpe.ee • info@norpe.ee

LATVIA Norpe Latvia Filiale Tel. +371 736 9827
www.norpe.com • info@norpe.lv