

INTRO RI

STAFF FRIENDLY SUPERMARKET CABINET.



Intro is a cabinet for large volumes. It is quick and easy to fill with products on castor shelving or pallets.



THE SIGN OF COOL QUALITY

Caring for the future

INTRO RI

- Castor shelving unit
- Large front opening makes filling of heavy products easier
- Front sill lifts high for ease of access

VISION COLLECTION

How to read the code:

R130-121-220-250
Front height Depth Height Length

Measures are centimeters.

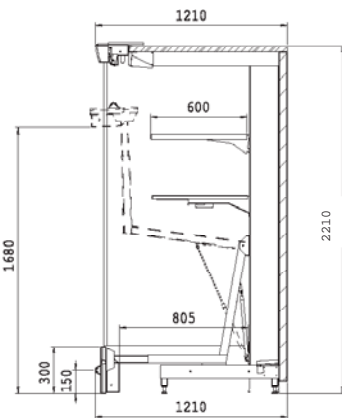

R130-121-221 INTRO

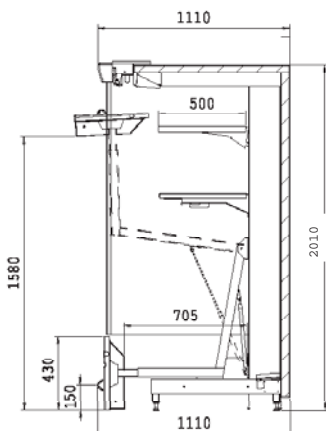

R143-111-201 INTRO

STANDARD FEATURES

- fan evaporator and expansion valves standard for R404A and CO₂ refrigerant
- fans
- defrosting rod
- defrost water connections for each unit, external diameter 40 mm
- thermometer
- overhead light fitting
- electricity switch box on the top of the cabinet
- full-length drainage kit
- standard cover plate Arc

TECHNICAL DATA

Front height Height Air Temperature	300 or 430 mm 2010 or 2210 mm +2...+4 °C or +4...+8 °C	Min power input W	¹⁾ Max. power input W	Length	Depth	¹⁾ Refr. area m ²
R130-111-201-188		756	876	1875	1107	3.2
R130-111-201-250		970	1114	2500	1107	4.3
R130-111-201-375		1430	1646	3750	1107	6.4
R130-111-221-188		756	876	1875	1107	3.2
R130-111-221-250		970	1114	2500	1107	4.3
R130-111-221-375		1430	1646	3750	1107	6.4
R130-121-201-188		756	876	1875	1207	3.8
R130-121-201-250		970	1114	2500	1207	5.0
R130-121-201-375		1430	1646	3750	1207	7.5
R130-121-221-188		756	876	1875	1207	3.8
R130-121-221-250		970	1114	2500	1207	5.0
R130-121-221-375		1430	1646	3750	1207	7.5
R143-111-201-188		756	876	1875	1107	3.2
R143-111-201-250		970	1114	2500	1107	4.3
R143-111-201-375		1430	1646	3750	1107	6.4
R143-111-221-188		756	876	1875	1107	3.2
R143-111-221-250		970	1114	2500	1107	4.3
R143-111-221-375		1430	1646	3750	1107	6.4
R143-121-201-188		756	876	1875	1207	3.8
R143-121-201-250		970	1114	2500	1207	5.0
R143-121-201-375		1430	1646	3750	1207	7.5
R143-121-221-188		756	876	1875	1207	3.8
R143-121-221-250		970	1114	2500	1207	5.0
R143-121-221-375		1430	1646	3750	1207	7.5

¹⁾ With 2 shelves and bottom plate



Standard shelf lighting.



Standard cover plate.



OPTIONAL EQUIPMENT

- expansion valves for other refrigerants
- energy saving fans
- mirrored end panel
- partition end panel
- bumper trim for end unit
- shelf with console 300, 400 and 500 mm
- shelf lights
- corner cover
- holders, dividers etc.
- night curtains motorised or manual
- automatic control system
- extension kit
- ticket strip holder
- external lighting equipment